

1500KG Heavy Duty Electric Pallet Jack Lithium Power

Ergonomic Smart Tiller, Replaceable Smart Lithium Battery & Robust Smart Chassis



NOBLELIFT The new model of electric pallet truck combines the advantages of manual and electric pallet trucks being the perfect electrical product for light and medium-duty material transportation in a most effortless and economical way.



TECHNICAL PROPERTIES

Item Code	PTE15N
Capacity	1500kg
Lift Height	115mm
Minimum Height	80mm
Fork Length	1150mm
Overall Length	1530mm
Fork Overall Width	685mm
Lifting speed full load / no load	20/25mm/s
Lowering speed full load / no load	50/40mm/s
Gradeability full load / no load	6/16%
Battery	24V/20Ah
Lifting motor	0.5kW
Weight	123kg
Warranty	1 year

NOTE: Whilst every care has been taken to ensure accuracy in this datasheet, due to technical effects, there could be some slight difference between the datasheet shown and the actual item. All graphics, specifications and descriptions are used for illustration purposes only. Any questions should you have, don't worry, our staff are always ready to help you.

Our Locations

Team Systems (Head Office)
121 Logis Boulevard
Dandenong South, VIC 3175
Tel: (03) 8791 5777

Team Systems VIC
Factory 7, 33 Lara Way
Campbellfield, VIC 3061
Tel: (03) 9357 0500

Team Systems NSW
79-85 Cowpasture Road
Wetherill Park, NSW 2164
Tel: (02) 9609 7782

Team Systems QLD
Unit 11, 28 Burnside Road
Yatala, QLD 4207
Tel: (07) 3807 9144

Team Systems SA
65 Manton Street
Hindmarsh, SA 5007
Tel: (08) 8340 4111

Team Systems WA
211 Bannister Rd
Canning Vale, WA 6155
Tel: (08) 9455 4855



1500KG Heavy Duty Electric Pallet Jack Lithium Power

Ergonomic & Smart Tiller Design

- Comfortable soft grips for comfort daily operation.
- Supported by the air spring and the tiller returns to its vertical position smoothly.
- All buttons are big and can be easily reached by operators even in case of working in gloves.
- Integrated PIN code panel with LCD display for smart control and operation.
- Speed reduction at different angles as well as the function of active tiller in its up-right position.
- The function of driving with the tiller in the vertical position helps with work in confined areas, especially in elevators and lorries without sacrificing of safety.

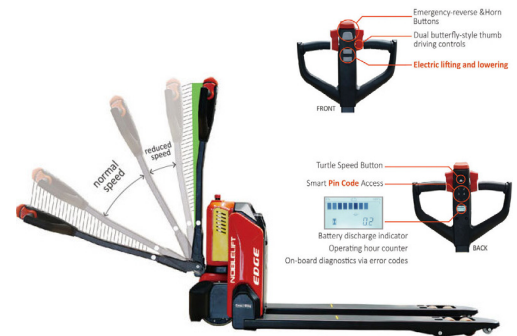

Smart Lithium Battery

- The Edge is equipped with a maintenance-free Lithium battery with optional different capacities for various applications.
- Fast and opportunity charging features the Edge works as easy as a hand pallet truck without special attention to the maintenance as other electric pallet trucks.
- The integrated BMS (Battery Management System) controls all important parameters and performance of lithium battery.
- Socket on the battery case for easy battery charging without the necessity to take the battery out.
- Fast and opportunity charging during brakes in operations increases working time.



Maintenance Friendly

- Convenient and fast access to any component of the truck, no elements are located in areas difficult to reach. No special tools are required.
- There are no hoses or pipes used in the hydraulic lifting circuit which significantly improves reliability and reduces the number of potential problems related to leakages through connectors or their seals.
- The truck is equipped with Curtis controller and CAN-bus technology makes the diagnostic and troubleshooting easier.
- Amount of working hours shown at the tiller helps to follow the maintenance schedule.



2

Robust Smart Design of Chassis

- Quick-connect wiring connects power with pushbutton controls for smooth operation.
- Permanently lubricated gear train delivers a long life with low maintenance.
- Offered in single phase and three phase units.
- Integrated slip clutch ensures continuous duty and tension control and protects transmission from overload.
- Gear trains are permanently lubricated for long life and minimal maintenance.

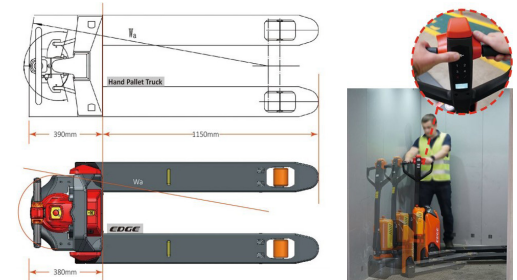

Gradeability Performance & Robustness

- Great performance on ramps even when they are fully loaded regardless their economic positioning.
- Each truck based on its performance level can climb on sufficient level of ramp.
- Strong steel apron protects the operator's feet during work and secures the truck's components from collisions with objects.



NOTE: Whilst every care has been taken to ensure accuracy in this datasheet, due to technical effects, there could be some slight difference between the datasheet shown and the actual item. All graphics, specifications and descriptions are used for illustration purposes only. Any questions should you have, don't worry, our staff are always ready to help you.

Our Locations

Team Systems (Head Office)
 121 Logis Boulevard
 Dandenong South, VIC 3175
 Tel: (03) 8791 5777

Team Systems VIC
 Factory 7, 33 Lara Way
 Campbellfield, VIC 3061
 Tel: (03) 9357 0500

Team Systems NSW
 79-85 Cowpasture Road
 Wetherill Park, NSW 2164
 Tel: (02) 9609 7782

Team Systems QLD
 Unit 11, 28 Burnside Road
 Yatala, QLD 4207
 Tel: (07) 3807 9144

Team Systems SA
 65 Manton Street
 Hindmarsh, SA 5007
 Tel: (08) 8340 4111

Team Systems WA
 211 Bannister Rd
 Canning Vale, WA 6155
 Tel: (08) 9455 4855



1500KG Heavy Duty Electric Pallet Jack Lithium Power

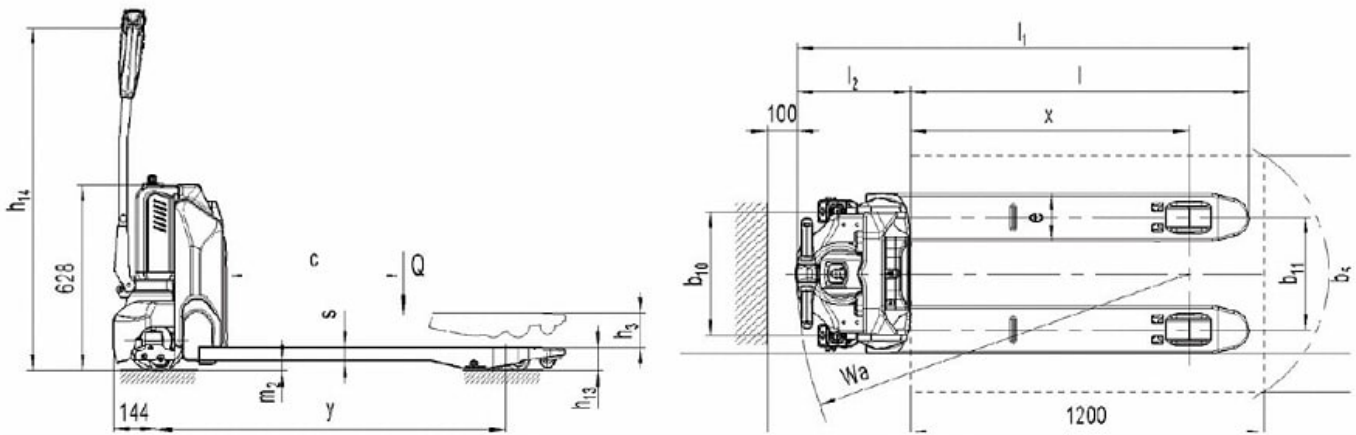

TECHNICAL PROPERTIES

No.	Item Description	PTE15N
1. FEATURED MARK		
1.1	Power	Lithium Battery
1.2	Operator Type	Pedestrian
1.3	Load Capacity/Rated Load (Q)	1500kg
1.4	Load Centre Distance (c)	600mm
1.5	Load Distance, Centre Of Drive Axle To Fork (x)	947mm
1.6	Wheelbase (y)	1185mm
2. WEIGHT		
2.1	Service Weight	123kg
2.2	Axle Loading, Laden Front/Rear	623 / 1000kg
2.3	Axle Loading, Unladen Front/Rear	96 / 27kg
3. TYRES, CHASSIS		
3.1	Tires	Polyurethane (PU)
3.2	Tire Size,Front (x w)	210 x 70mm
3.3	Tire Size,Rear (x w)	80 x 93mm (80 x70mm)
3.4	Additional Wheels (Dimensions) (x w)	80 x 30mm
3.5	Wheels,Number Front/Rear (X = Driven Wheels)	1X / 2 (1X / 4) or 1X + 2 / 2 (1X+ 2 / 4)
3.6	Tread, Front (b ₁₀)	430mm
3.7	Tread, Rear (b ₁₁)	380mm

3

NOTE: Whilst every care has been taken to ensure accuracy in this datasheet, due to technical effects, there could be some slight difference between the datasheet shown and the actual item. All graphics, specifications and descriptions are used for illustration purposes only. Any questions should you have, don't worry, our staff are always ready to help you.

Our Locations

Team Systems (Head Office)
121 Logis Boulevard
Dandenong South, VIC 3175
Tel: (03) 8791 5777

Team Systems VIC
Factory 7, 33 Lara Way
Campbellfield, VIC 3061
Tel: (03) 9357 0500

Team Systems NSW
79-85 Cowpasture Road
Wetherill Park, NSW 2164
Tel: (02) 9609 7782

Team Systems QLD
Unit 11, 28 Burnside Road
Yatala, QLD 4207
Tel: (07) 3807 9144

Team Systems SA
65 Manton Street
Hindmarsh, SA 5007
Tel: (08) 8340 4111

Team Systems WA
211 Bannister Rd
Canning Vale, WA 6155
Tel: (08) 9455 4855



1500KG Heavy Duty Electric Pallet Jack Lithium Power

TECHNICAL PROPERTIES

4. DIMENSIONS

4.1	Lift Height (h_3)	115mm
4.2	Height Of Tiller In Drive Position Min. / Max. (h_{14})	700/1160mm
4.3	Height, Lowered (h_{13})	80mm
4.4	Overall Length (l_1)	1530mm
4.5	Length To Face Of Forks (l_2)	380mm
4.6	Overall Width (b_1)	685mm
4.6	Fork Dimension (s/e/l)	47/160/1150mm
4.8	Width Across Forks (b_5)	685mm
4.9	Ground Clearance, Centre Of Wheelbase (m_2)	33mm
4.10	Aisle Width For Pallets 800x1200mm Lengthways (Ast)	2000mm
4.11	Turning Radius (Wa)	1330mm

5. PERFORMANCE

5.1	Travel Speed, Laden / Unladen	4.6/4.8km/h
5.2	Lift Speed, Laden / Unladen	0.020/0.025m/s
5.3	Lowering Speed, Laden / Unladen	0.05/0.04m/s
5.4	Gradeability, Laden / Unladen	6/16%
5.5	Service Brake	Electromagnetic

6. MOTORS

6.1	Drive Motor Rating S2 60min	0.65kW
6.2	Lift Motor Rating At S3 I 0%	0.5kW
6.3	Battery Voltage, Nominal Capacity K/s	24/20V/Ah
6.4	Battery Weight (Minimum)	4.6kg
6.6	Energy Consumption Acc. To VDI Cycle	0.22kWh/h

7. Battery

7.1	Standard Battery	24V/20Ah Li-ion
7.2	Standard Charger	24V/5A

8. ADDITIONAL

8.1	Type Of Drive Control	DC speed Control
8.2	Sound Level At Driver's Ear Acc. To En 12053	<70dB(A)

NOTE: Whilst every care has been taken to ensure accuracy in this datasheet, due to technical effects, there could be some slight difference between the datasheet shown and the actual item. All graphics, specifications and descriptions are used for illustration purposes only. Any questions should you have, don't worry, our staff are always ready to help you.

Our Locations

Team Systems (Head Office)
121 Logis Boulevard
Dandenong South, VIC 3175
Tel: (03) 8791 5777

Team Systems VIC
Factory 7, 33 Lara Way
Campbellfield, VIC 3061
Tel: (03) 9357 0500

Team Systems NSW
79-85 Cowpasture Road
Wetherill Park, NSW 2164
Tel: (02) 9609 7782

Team Systems QLD
Unit 11, 28 Burnside Road
Yatala, QLD 4207
Tel: (07) 3807 9144

Team Systems SA
65 Manton Street
Hindmarsh, SA 5007
Tel: (08) 8340 4111

Team Systems WA
211 Bannister Rd
Canning Vale, WA 6155
Tel: (08) 9455 4855

